



Case IH
1260 – 32/36 Row
Planter Scale

Instructions
And
Repair Parts



Ft. Atkinson, Wisconsin USA



Panningen, The Netherlands

www.digi-star.com

TABLE OF CONTENTS

INTRODUCTION	1
Charging Battery and Welding	1
SCALE KIT MOUNTING INSTALLATION – 32/36 ROW	2
Front Support	3
Middle and Catwalk Support	4
JUNCTION BOX MOUNTING	5
Connect Load Cell and J-Box Cable	5
Installing wires into Terminal Block	5
INDICATOR MOUNTING	6
Power Connection:	6
Load Cell Connection:	6
TROUBLE SHOOTING	7
How to Check the Drill Scale after Installation	7
REPAIR PARTS	8
406310 Kit – Scale CNH1260, 32, 36 Row	8
406311 Kit – Scale CNH1260, 32, 36 Row, Indicator in Tractor Cab	8
INDICATOR SWIVEL MOUNT	9
LICENSE AGREEMENT	10

All rights reserved. Reproduction of any part of this manual in any form whatsoever without Digi-Star's express written permission is forbidden. The contents of this manual are subject to change without notice. All efforts have been made to assure the accuracy of the contents of this manual. However, should any errors be detected, Digi-Star would greatly appreciate being informed of them. The above notwithstanding, Digi-Star can assume no responsibility for errors in this manual or their consequence.

© Copyright! 2008 Digi-Star, Fort Atkinson (U.S.A.).

INTRODUCTION

Congratulations on the purchase of your new Digi-Star Planter Scale for Case IH 1260 planter in 32/36 rows.

The scale system is specially designed to weigh the bulk-fill seed hopper. The scale will record and monitor seed weight going into or out of the central hopper.

This scale system is covered by the following US patents: 6732667, 7059258 and 7273017. The single-use license is included with this document (see page 10).

 This **SAFETY ALERT SYMBOL** indicates important safety messages in the manual. When you see this symbol, be alert to the possibility of **PERSONAL INJURY** and carefully read the message that follows.

WARNING NEVER OPERATE WITHOUT ALL COVERS, SHIELDS AND GUARDS IN PLACE. KEEP HANDS, FEET AND CLOTHING AWAY FROM MOVING PARTS. FAILURE TO HEED MAY RESULT IN SERIOUS PERSONAL INJURY OR DEATH.

Some covers and guards have been removed for illustrative/photographic purposes only in this manual.

For information on ordering repair parts, refer to Parts Section in this book.

This supersedes all previous published instructions.



Important!

Charging Battery and Welding

Disconnect all cables from the weighing indicator before charging the battery or welding on the machine. If cables are left connected, the weighing indicator and connected load cells could be damaged.

Important: Do not weld near indicator, load cells or cables; remove from area to be welded. Place ground close to area to be welded to prevent current from passing through electronic parts.

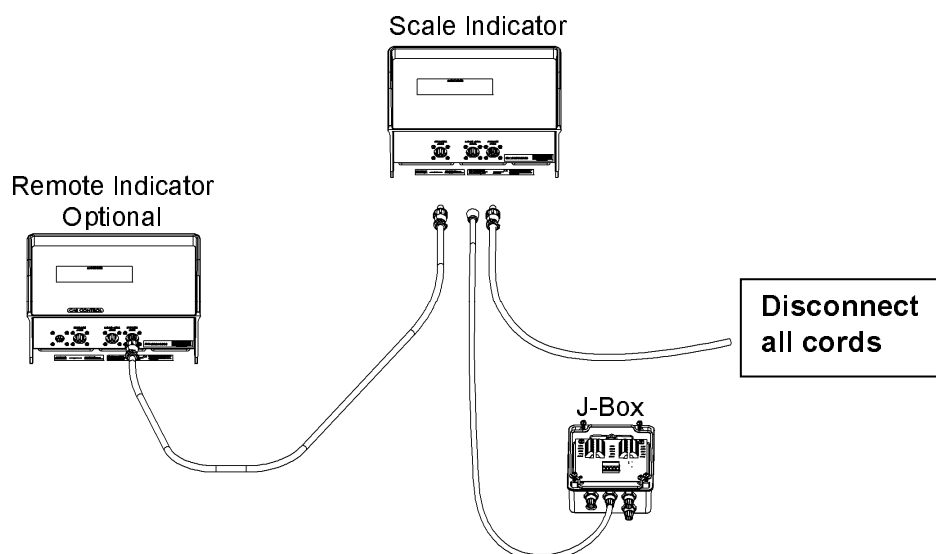

SCALE KIT MOUNTING INSTALLATION - 32/36 ROW

The Case IH 1260 - 32/36 Row Scale Kits require mounting six load cells. The illustration below highlights the location of each load cell.

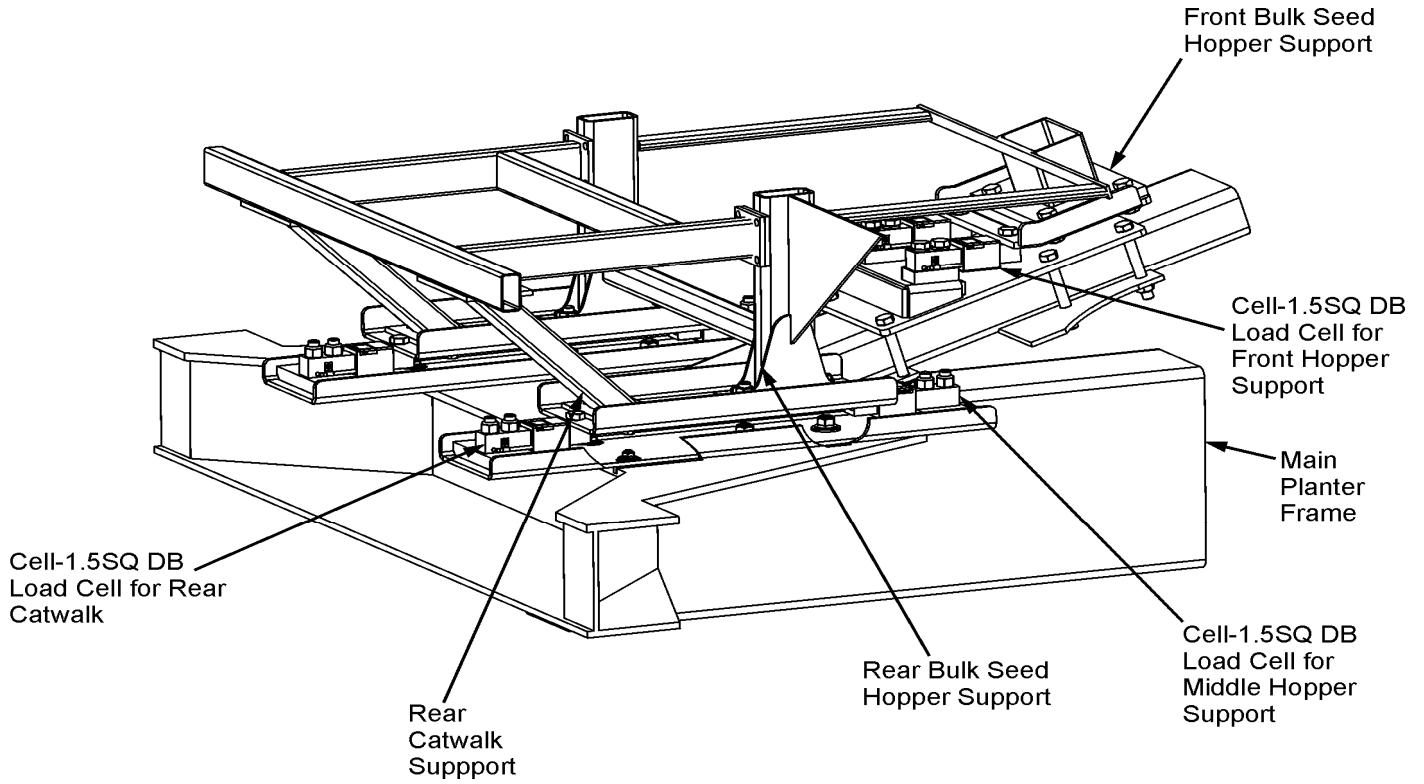

Front Support

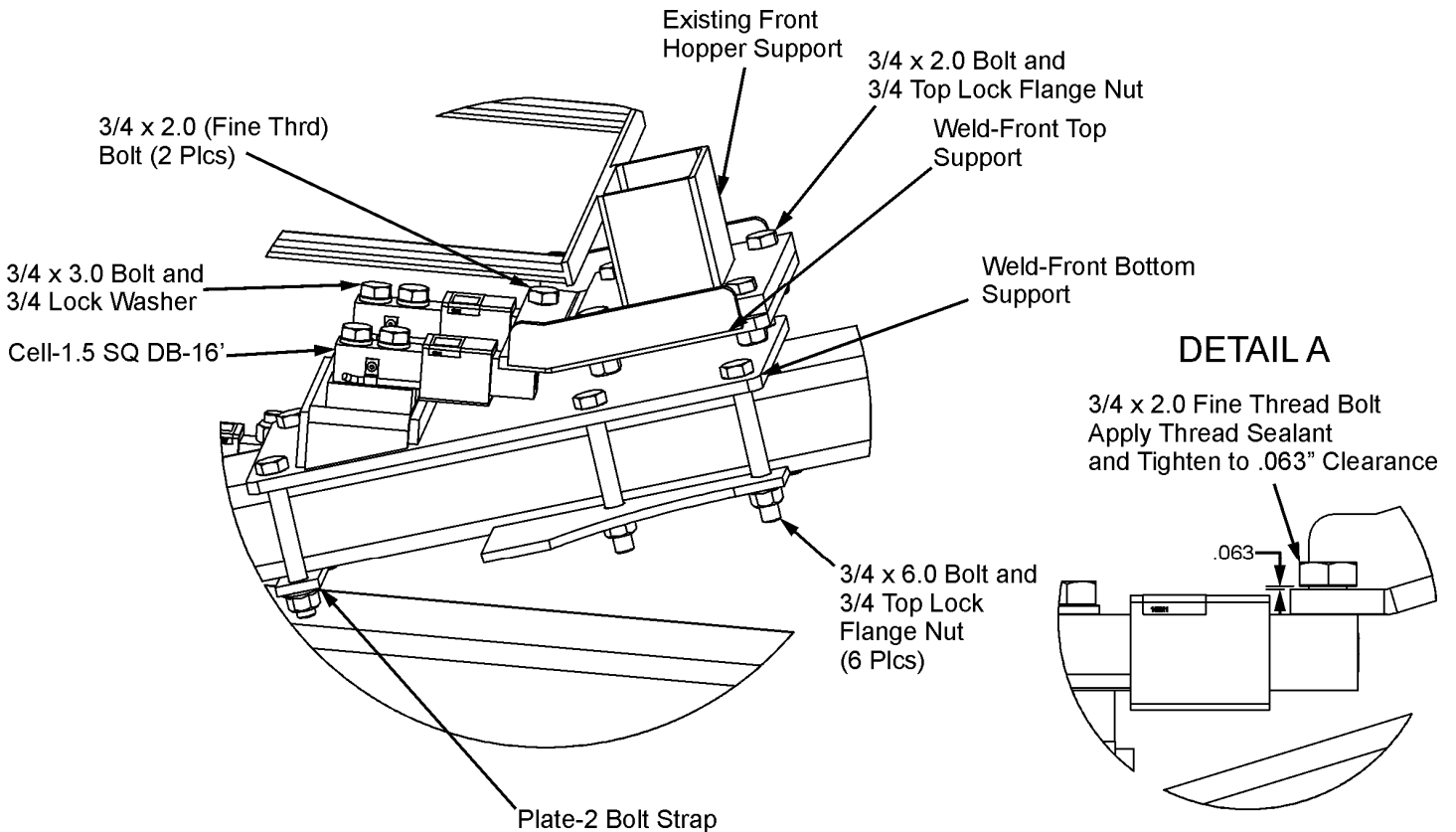

1. If possible, fold out planter wings as this allows easier access to the hopper supports.
2. **Loosen** but do not remove all hardware that attaches the hopper support to the planter main frame, i.e. front hopper support bolts, middle support bolts and catwalk supports.
3. Support/lift the front hopper support.

IMPORTANT: The lift chains, bucket attachment, loader/skid steer, winch or jack must be capable of lifting and controlling 1000 lbs.

When the front hopper structure is supported, remove the bolts from the front and middle supports.

IMPORTANT: Do not remove the rear catwalk support as these bolts keep the front hopper support from shifting rearward.
4. Jack the front up so that the front seed hopper support is off of the frame 2-3 inches.
5. Install load cells to the front bottom support with 3/4" x 3.0" bolts and 3/4" lock washers. Tighten bolts.

IMPORTANT: "Bending Direction" decal on the end of the load cell must point **DOWNWARD**.
6. Install the front bottom support to the planter main frame with 3/4" x 6.0" bolts and 3/4" top lock flange nuts. Make sure to install the Plate 2-Bolt Strap for the rear 3/4 x 6.0" bolts.
7. Install front top load cell support to existing hopper front frame support with four 3/4" x 2.0" bolt and 3/4" top lock flange nuts. Secure front top support to load cell with 3/4" x 2.0" fine threaded bolt. Apply thread sealant and tighten to 1/16" clearance. See Detail A.
8. Align all supports and load cell; tighten all hardware.

Middle and Catwalk Support

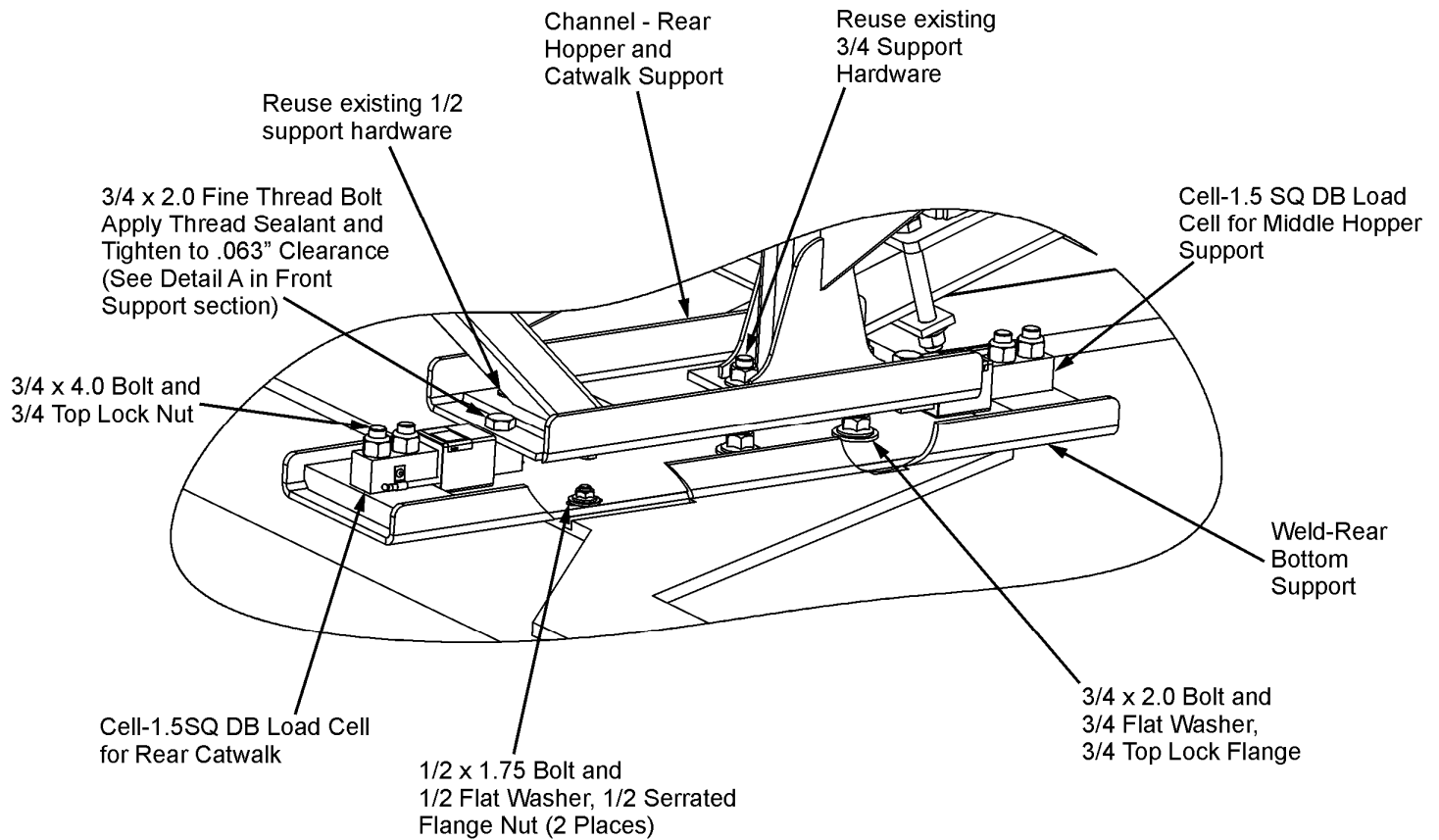

9. Remove two bolts that hold the existing catwalk support to catwalk frame. Raise catwalk two inches.
10. Mount the rear hopper and catwalk channel to the underside of the existing catwalk and middle hopper support. Reuse existing 1/2" x 3/4" bolts and hardware.
11. Slide rear bottom support on top of the planter main frame and secure with 1/2" and 3/4" hardware (see above diagram)
12. Mount Load Cell-1.5SQ DB to the bottom rear support with 3/4" x 4.0 bolt and 3/4" top lock nut.
IMPORTANT: Make sure the arrow on the end of the weigh bar points **DOWNWARD**. Mount short load cell end to rear hopper channel with 3/4" x 2.0" fine thread bolt. Apply thread sealant and tighten to 1/16" clearance. See Detail A on page 3.
13. Install 3" tall c-channels to the rear catwalk air hose canister using 3/8" x 1.5" and 3/8" serrated flange nuts. The c-channels will lower the air canister down in order for the hoses to remain slack with the scale kit.

JUNCTION BOX MOUNTING

The junction box is water resistant, not water-proof. It should be mounted to avoid submersion during wet weather and to avoid physical abuse. The junction box can be mounted on the front or rear of the drill, planter or seeder. All load cell cables must reach the J-Box. Install by removing the double sided tape backing and apply to cleaned surface.

Connect Load Cell and J-Box Cable

1. Route front and rear load cell cables to J-box location. Make sure they are not bound or pinched. Cable tie (customer provided) load cell cables in place.
2. Insert load cell and J-box cables through each of the water-tight strain-reliefs.
3. Remove each terminal block from the J-box.
4. Connect wires of the same color to the same terminal block. See instructions below.
5. Install terminal block into the J-box as shown (location not important).
6. Tighten nuts on the water-tight strain-reliefs.
7. Assure that gasket is properly installed in the cover.
8. Attach cover using 4 screws (provided).

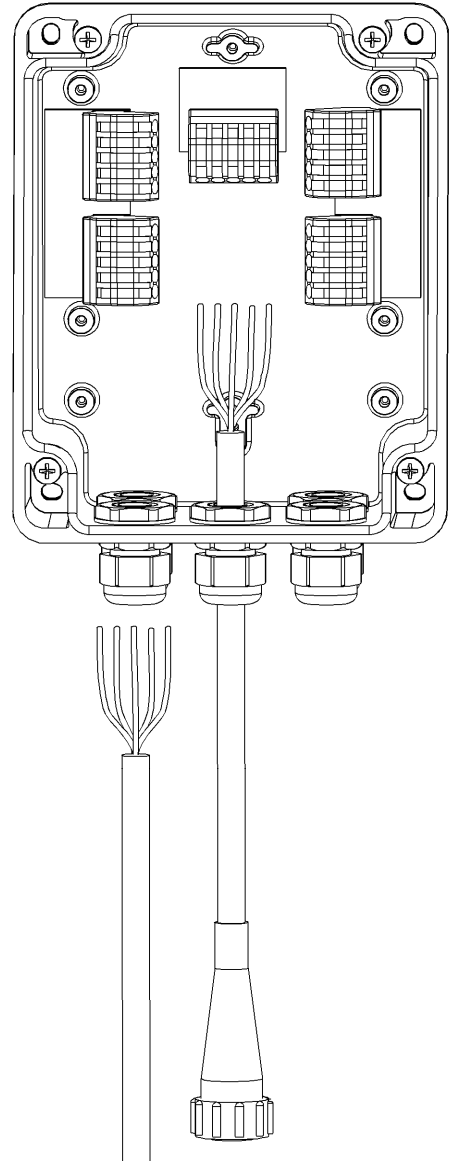

Installing wires into Terminal Block

1. Open levers 90° to locked position.
2. Insert individual wires into terminal.
3. Close lever.
4. Tug wire to assure solid connection.

Note: Wire strip length is 7/16" (11mm).

406232	J-Box Lever Nut 4Pt (Planter)
141837	Cable - 30Ft J-Box
406074	Cable - 45Ft J-Box
403335	Cable - Power 17Ft 2-Wire
406073	Cable - Power 36Ft 2-Wire
406072	Cable - Power 6Ft 2-Wire
824316	Cable - 15Ft-J-Box
145096	Cable - 70Ft-J-Box
406276	Cable - Power 65Ft 2-Wire

INDICATOR MOUNTING

The scale indicator can be mounted in the tractor cab or on the planter with swivel mounting pack (406983). Depending on which kit you purchase, two cables must be connected to the indicator bottom panel, J-Box and power cables. Refer to Indicator Manual D3831-US for details of indicator mounting options and connection of power cord.

INDICATOR MOUNTINGS

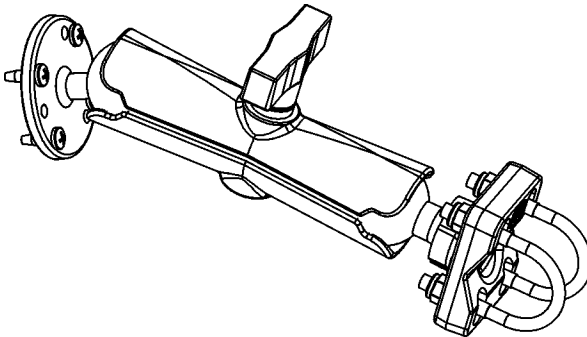

U-BOLT RAM MOUNT

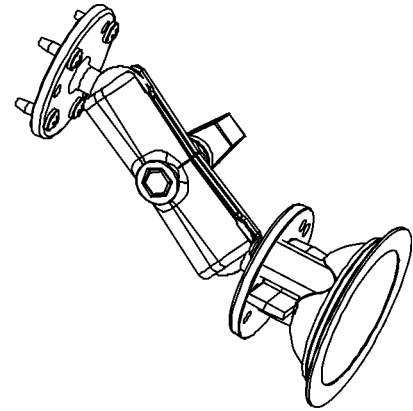

TRACTOR CAB MOUNTING

1. Bolt the readout in the cab, or mount the swivel bracket on the drill, planter or seeder.
2. Install power cord to a 12-volt negative ground battery.
3. Route J-box cable to indicator and install to indicator bottom panel.
4. Program indicator with set-up #145023 and calibration #22500 (see Indicator Manual).

Power Connection:

The power cable should be connected directly to a vehicle battery or regulated power supply. The scale end of the power cable is attached to the J901 connector located on the bottom panel of the indicator.

Connect the RED wire from the power cable to +12 VDC and the BLACK wire to GROUND. The indicator is fused internally at 4 amps.

Power Cable Connections:

Wire color	Wire Function
Red	Battery (+12 VDC)
Black	GROUND

Load Cell Connection:

The indicator is designed to operate with strain gage load cells. The indicator will normally be supplied with a "J-BOX" cable going between the scale and the load cell junction box. Extension kits are available from your dealer in various lengths.

Load Cell Wire	Digi-Star	Function
1	RED	+EX
2	GREEN	-SIG
3	WHITE	+SIG
4	BLACK	-EX
5	CLEAR	SHIELD

TROUBLE SHOOTING

How to Check the Drill Scale after Installation

For the first test, lift the drill, planter or seeder all the way up, to a level area. Put 200-250 pounds of weight on the right side, then compare it to the left. Both sides should be within four to six pounds of each other.

- If the weight is not within the four to six pound range, inspect the scale system for loose or misalign mounts.

The second test is to lift the drill, planter or seeder to a level area and zero the scale. Lift the drill/planter/seeder up and down two to three times, checking to see if the scale zeros out. Each time the scale is in the up position, it should be within four to six pounds.

If further assistance is necessary, please call Digi-Star, LLC at 920-563-9700.

***The example we are using is 2000 lbs of seed evenly filled in both hoppers. There is 25 lbs of seed left from the last fill.

Push the "Start" button. The screen will show zero, and the arrow is now pointing to "Net" on the screen. This is a temporary zero point to start loading the planter with seed. You will now fill 1000 lbs of seed into the left hopper.

Push the "Stop" button, the readout now reads 1025 lbs of seed inventory.

Push the "Start" button again. The screen will say zero again. Load another 1000 lbs of seed into the right side.

Now push "Stop" and the screen will read 2025 lbs of seed. The number will decrease as the seed is planted.

REPAIR PARTS

406310 Kit – Scale CNH1260, 32, 36 Row

406311 Kit – Scale CNH1260, 32, 36 Row, Indicator in Tractor Cab

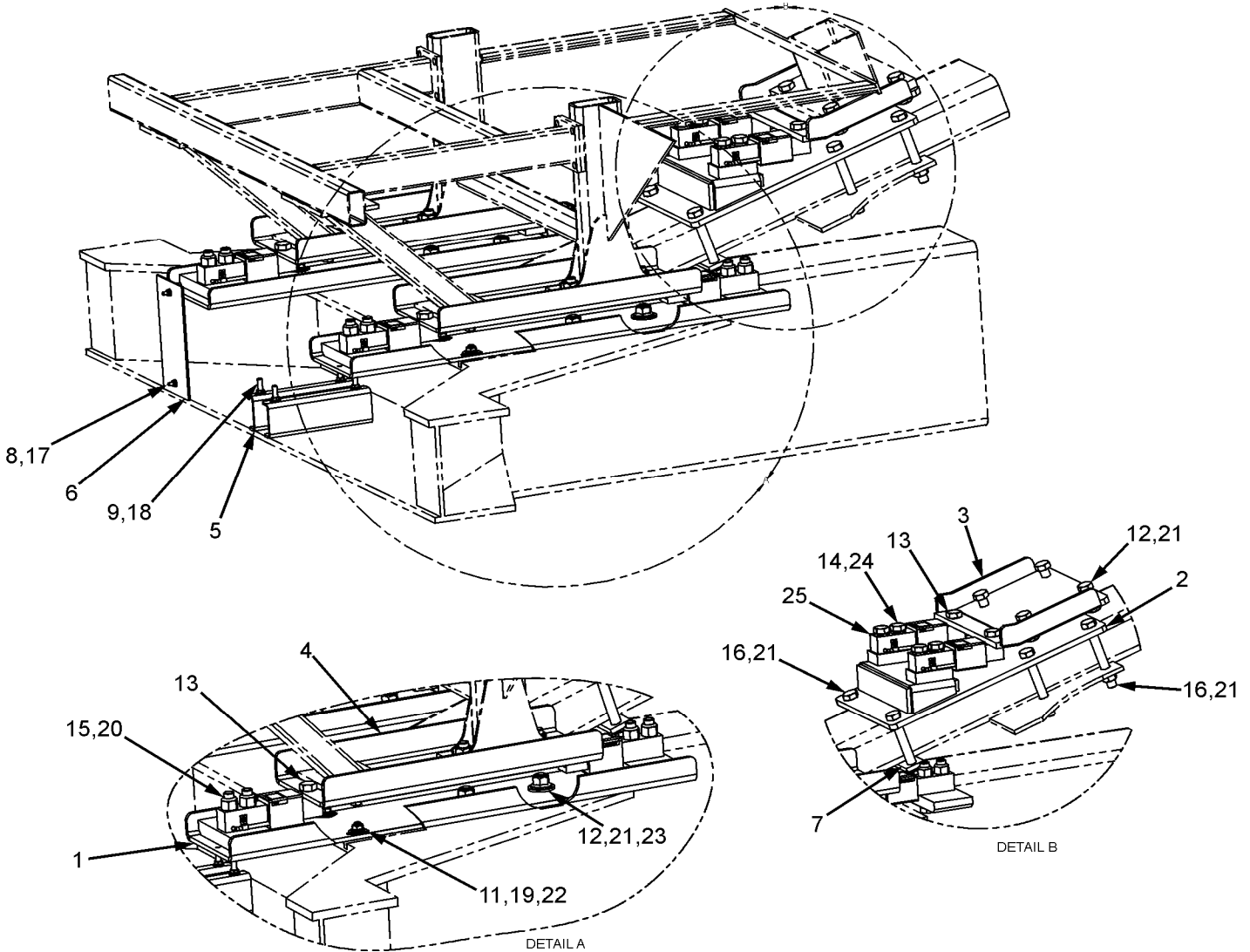

KEY	QTY.	PART NO.	DESCRIPTION	KEY	QTY.	PART NO.	DESCRIPTION
1	2	406935	Weld-Rear Bottom Suppt (CNH1260)	14	4	405272	Scr-3/4-10 x 3.0 HHCS ZP Grd 5
2	1	406942	Weld-Front Bottom (CNH1260)	15	8	405895	Scr-3/4-10 x 4.0 HHCS ZP Grd 5
3	1	406945	Weld-Front Top Suppt	16	6	407001	Scr-3/4-10 x 6.0 HHCS ZP Grd 5
4	2	406940	Brkt-Channel Bottom 5/16	17	2	405084	Nut-1/4-20 Ser Flange ZP
5	2	407110	Brkt-Hose Suppt	18	4	404705	Nut-3/8-16 Ser Flange ZP
6	1	407111	Plate-Box Cover	19	8	406085	Nut-1/2-13 Ser Flange ZP
7	1	407000	Plate-2 Bolt Suppt	20	8	405921	Nut-3/4-10 Top-Lock ZP
8	2	400036	Scr-1/4-2 x 3/4 HHCS ZP	21	18	405988	Nut-3/4-10 Top-Lock Flange ZP
9	4	406401	Scr-3/8-16 x 1.5 HHCS ZP Grd 5	22	12	405053	Wash-1/2 Flat Wide ZP
10	4	406459	Scr-1/2-13 x 1.5 HHCS ZP Grd 5	23	8	405923	Wash-3/4 Flat ZP
11	4	407011	Scr-1/2-13 x 1.75 HHCS ZP Grd 5	24	4	405273	Washer-3/4 Split Lock ZP
12	12	406301	Scr-3/4-10 x 20 HHCS ZP Grd 5	25	6	404284	Cell – 1.5 Sq. DB-21 Ft
13	6	406067	Scr-3/4-16 x 2.0 HHCS ZP Grd 5				

INDICATOR SWIVEL MOUNT

406983 – 1.5” Ram Mount with U-Bolt Mount

406385 – 1” Ram Mount with Suction Cup

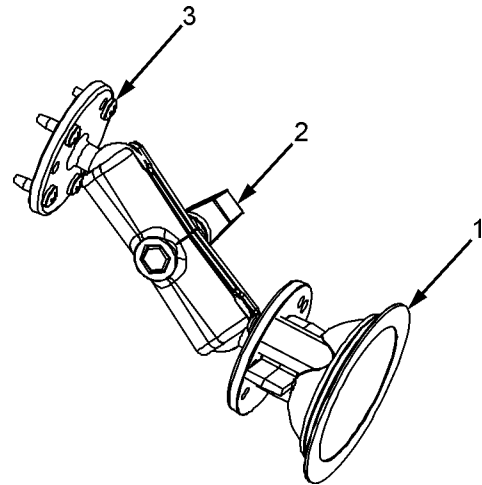
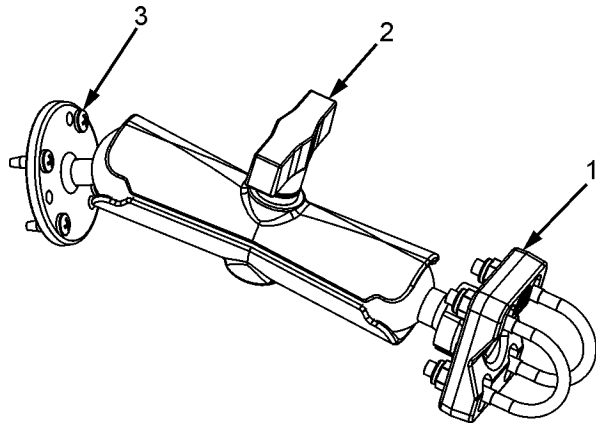

406983			
KEY	QTY.	PART NO.	DESCRIPTION
1	1	406981	Mount – 1.5 Ram with U-Bolt
2	1	403314	Mount – Ram-111 1.5” Ball 7.3” Lg
3	4	403779	SCR #10 x 5/8” PHSTS 48-2 Blk ZP

406385			
KEY	QTY.	PART NO.	DESCRIPTION
1	1	404230	Ram Suction Cup with Twist Lock
2	1	403180	Assembly – 1” Ram Mount
3	4	403779	Scr - #10 x 5/8 PHSTS 48-2 Blk ZP

LICENSE AGREEMENT

IMPORTANT NOTICE: Acceptance and use of the enclosed electronic scale products (hereinafter referred to as “Purchased Product”) constitutes your agreement to the following terms and conditions. Please carefully read the following terms and conditions before using or reselling the Purchased Product.

- Limited License. Digi-Star, LLC, a Wisconsin limited liability company (“Owner”) is the owner of the following U.S. Patents related to grain drills: 6,732,667, 7,059,258, 7,273,017, 7,357,087, 7,448,335, 7,523,710 and any other patents which result from continuation applications thereof (“Patents”). Owner hereby grants to the customer (“Customer”) a non-exclusive, non-transferable, revocable, limited license to use the technology described in the Patents to use the Purchased Product to assemble a seed planter product covered by the Patents (“Licensed Product”), and to sell and offer for sale one (1) unit of the Licensed Product in accordance with the terms and conditions set forth herein. Alternatively, Customer may resell the Purchased Product to another entity for the purpose of that entity assembling one (1) unit of a Licensed Product under a permitted sublicense from the Customer with the same terms as this Agreement. If Customer would like to assemble, use, sell or offer for sale more than one (1) Licensed Product, or resell more than one (1) Purchased Product, Customer understands and agrees that it must purchase another Purchased Product from Owner or acquire a separate license by requesting and purchasing another unit of the same SKU number that resulted in this purchase.
- Acceptance of Terms and Conditions. Customer warrants that it has the authority to enter into this binding agreement. If Customer does not accept the terms and conditions, Customer shall not use the Purchased Product. Customer understands and agrees that if it uses the Purchased Product as permitted herein, it will be deemed to have accepted these terms and conditions and they shall become a binding agreement.
- Limitations on Use. Customer agrees that it will use the Licensed Product only as expressly authorized in this Agreement, and that any use not expressly authorized in this Agreement is prohibited. Customer agrees that it will not: (i) loan, rent, lease, assign, sublicense, distribute or otherwise transfer its rights under this Agreement to a third party, other than to resell the Purchased Product to another entity for the purpose of that entity assembling one unit of a Licensed Product; (ii) copy or reproduce the Licensed Product; or (iii) grant any sublicenses other than to an end user of the Licensed Product, or to another entity for the purpose of that entity assembling one unit of a Licensed Product. Customer agrees to use reasonable efforts to prevent any unauthorized use or copying of the Licensed Product and will notify Owner immediately upon learning of any such unauthorized use or copying. Customer’s obligations under this section shall survive any termination of this Agreement or the license granted hereunder. Any unauthorized use of the Licensed Product will result in, among other things, the immediate termination of this license.
- Ownership of Proprietary Rights. Customer acknowledges that the Licensed Product is covered intellectual and/or proprietary rights, and that all such intellectual and proprietary rights are owned by Owner. Customer hereby acknowledges that it has no rights in the foregoing except as expressly granted herein.
- NO WARRANTY. Customer agrees to fully test and evaluate the Purchased Product and Customer acknowledges and agrees that Owner will not assume any product liability or any other liability for the Purchased Product or the Licensed Product. The Purchased Product is furnished to Customer “AS IS.” **Except as otherwise provided by separate documentation, OWNER MAKES NO WARRANTIES, EITHER EXPRESS OR IMPLIED, WITH RESPECT TO THE PURCHASED PRODUCT.** Customer agrees that Owner shall have no liability resulting from Customer’s use of the Purchased Product for any indirect damages including consequential, incidental or special damages for loss of profit, good will or otherwise. Customer shall indemnify and hold Owner harmless from any and all losses, expenses, damages, costs or expenses of any kind, including but not limited to reasonable attorneys’ fees, incurred by Owner resulting from Customer’s use of the Purchased Product. **NO ORAL OR WRITTEN STATEMENTS MADE BY OWNER OR ITS EMPLOYEES INCLUDING BUT NOT LIMITED TO STATEMENTS REGARDING CAPACITY, SUITABILITY FOR USE, OR PERFORMANCE OF THE PURCHASED PRODUCT SHALL BE DEEMED A WARRANTY OR REPRESENTATION BY OWNER FOR ANY PURPOSE NOR GIVE RISE TO ANY LIABILITY OR OBLIGATION OF OWNER.**
- Remedies for Violations. Owner reserves the right to seek all remedies available at law and in equity for violations of this Agreement, including but not limited to the right to recover the Licensed Product.
- Fees. In consideration for the rights granted under this Agreement, Customer has paid a license fee that was included in the amount invoiced to the Customer for the sale of the Purchased Product.
- Entire Agreement. Except as expressly stated herein to the contrary, this Agreement constitutes the entire agreement between the parties regarding the subject matter hereof, and no verbal or written prior statements or representations of any sort made by any party shall be effective or valid for any purpose whatsoever. This Agreement may be amended only upon the mutual consent of all parties in writing.
- Severability. If any provision of this Agreement shall be held to be invalid, illegal or unenforceable, the validity, legality and enforceability of the remaining provisions shall not in any way be affected or impaired thereby. The failure of any party to enforce any provision of this Agreement shall not be considered a waiver thereof, nor shall such failure prevent the future enforcement of any such provision.
- Governing Law. This Agreement and the relationship between the parties shall be governed in all respects by the laws of the State of Wisconsin and the United States of America. The parties consent to the jurisdiction and venue of the Wisconsin and United States courts located in Wisconsin for resolution of any dispute under to this Agreement.

Use or sale of the Licensed Product or of Purchased Product shall bind Customer to all terms and conditions herein without the necessity of signatures on this Agreement.